

# How to add length to your pattern (while keeping it's shape)

an itty bitty tutorial by Jona Giammalva

This is a tutorial specifically made to show you how to lengthen your Sunny Scallop Dress pattern but this manner of lengthening a pattern can be used for many other patterns as well.

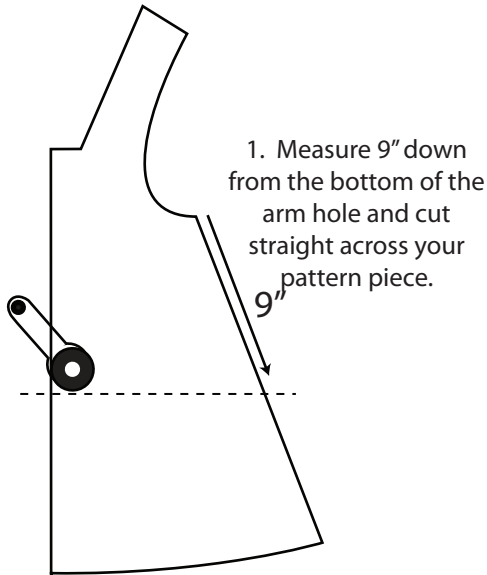

1. Measure 9" down from the bottom of the arm hole and cut straight across your pattern piece.

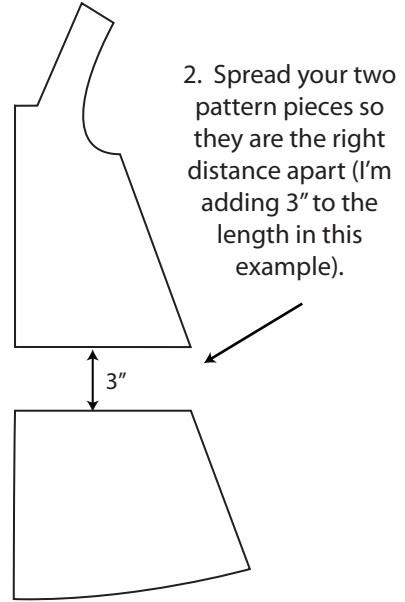

2. Spread your two pattern pieces so they are the right distance apart (I'm adding 3" to the length in this example).

3. Tape a paper strip across the middle to bridge the gap by the amount you want to add (i.e. if you're adding 3" to the length, cut a 4" high strip so you have room to place the tape and just have 3" show through).

Tape strip to the side at the bottom. Make it long enough to meet up with the previous strip. (as shown).

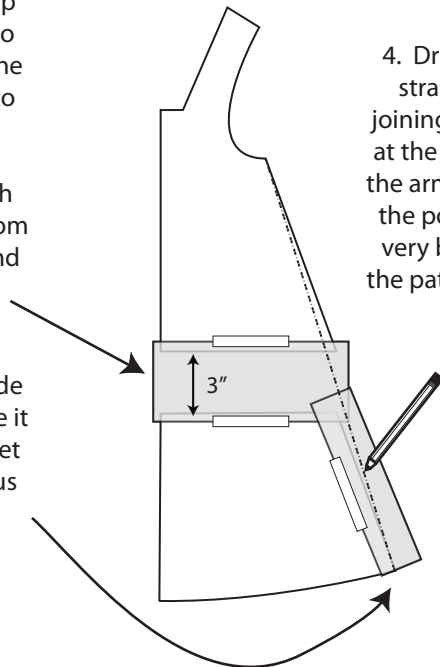

4. Draw a long straight line joining the point at the bottom of the arm hole with the point at the very bottom of the pattern piece.

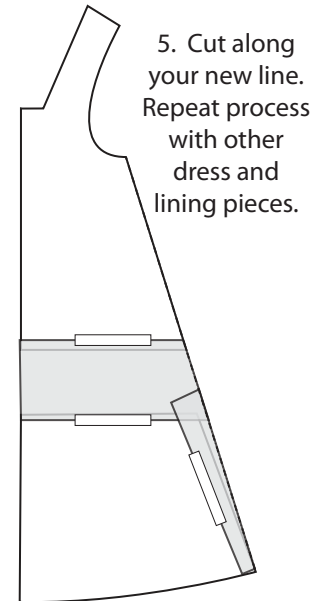

5. Cut along your new line. Repeat process with other dress and lining pieces.

If you're making the scalloped version of my Sunny Scallop Dress you will need to make a slight adjustment on the angle at the side of your scallop piece too (not the folding edge).

Tape paper on, mark angle so it matches your dress piece.



Cut along mark. Done.

